



ANI series

WaveDynamics™ Dante audio network interface

Installation Guide

The ANIxx are Dante audio network interfaces, supporting four (ANI44XT) networked audio channels. The installation of this optional interfaces allows these amplifiers to be integrated into any DANTE enabled AV network and flawlessly transfer digital audio with any compatible product on the market, ranging from music sources to microphone systems, mixers, and many more.

These interfaces come delivered as a complete installation kit, including all required accessories for installation into the supporting devices.



The installation of the ANI module may only be performed by qualified technicians.

Incorrect installation can lead to permanent damage or incorrect functioning of the equipment.

Packaging contents

- 1x ANIxx main interface board
- 1x ANIxx ethernet connection board
- 1x ANIxx ethernet connection cable (24 cm) - VEXO
- 1x ANIxx ethernet connection cable (66 cm) - SMA/SMQ/PMQ
- 1x ANIxx Keystone ethernet connection cable

Included installation accessories:

- 2x Nylon snap-in spacer
- 1x M3 spacer
- 1x Spring washer
- 1x M3 nut
- 2x Cable tie

Table of contents

Installation guide MFA	2
Installation guide SMA/SMQ/PMQ	5
Installation guide VEXO	10

ANI series

Installation Guide MFA

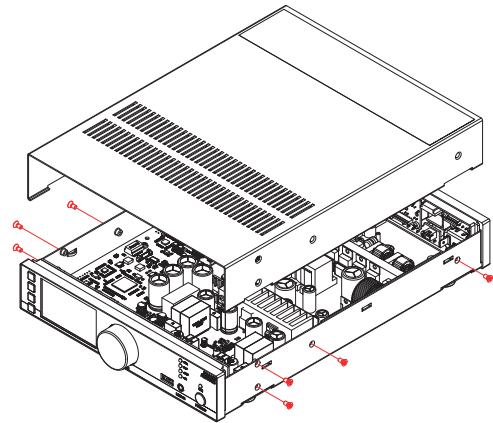
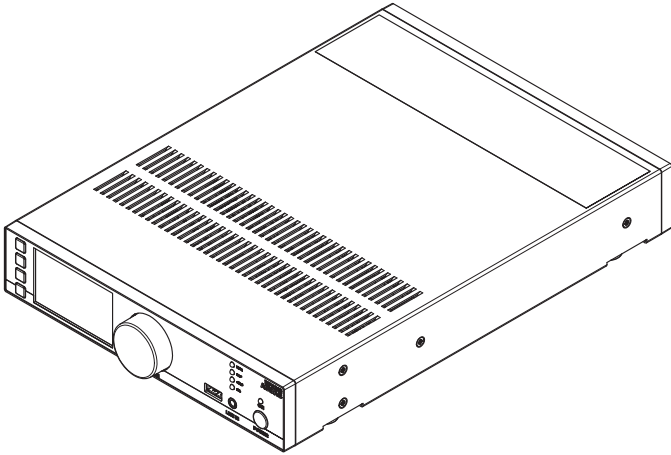

Step 1: ATTENTION

Make sure the amplifier is powered off and the power inlet is disconnected from the mains power before the enclosure is opened

Step 2: chassis cover

Open the amplifier housing by carefully removing the screws from the side panels of the unit. Once the screws have been removed, pull the sides out. Check whether the lip at the bottom is free. Once it's free, lift the cover up.

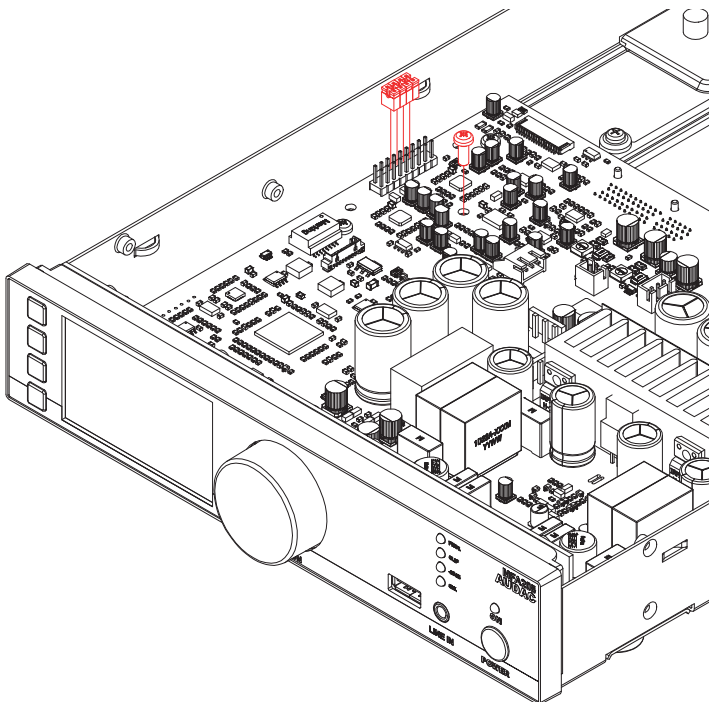

Step 3: Removal

Remove the indicated jumpers and screw from the main circuit board

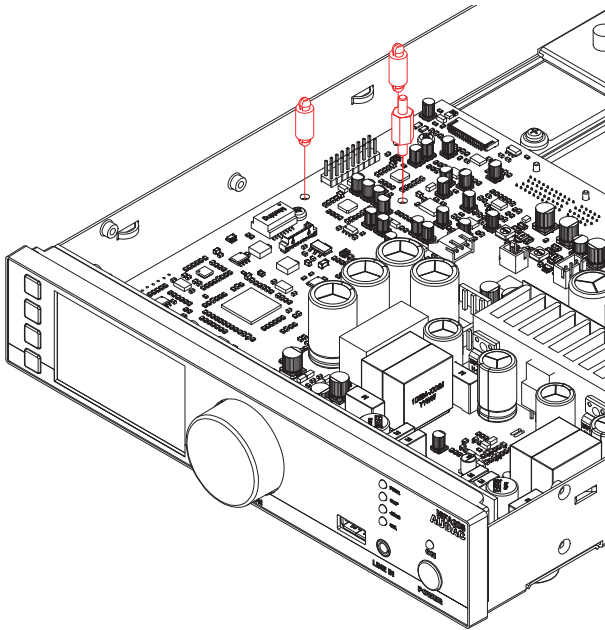

Step 4: Spacer

Insert the M3 spacer and both nylon snap-in spacers into the appropriate holes in the circuit board as indicated in the image above.

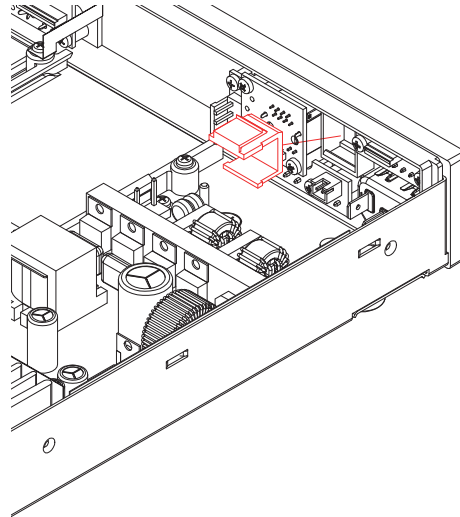

Step 5: Keystone cover

Remove the keystone cover at the back of the device by pressing the top lip down with a flat screwdriver before tilting the cover into the device.

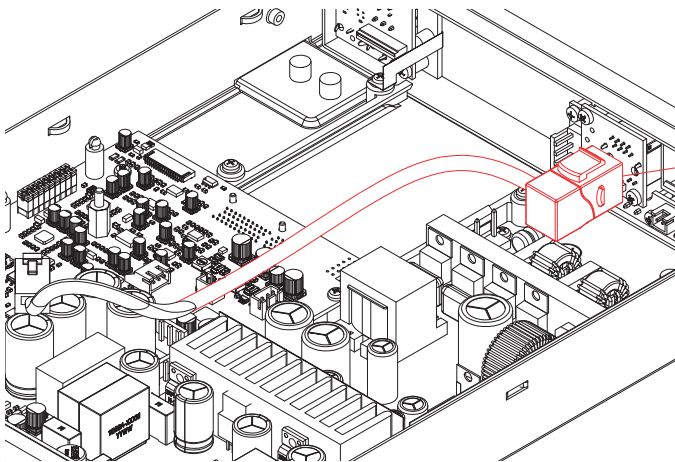

Step 6: Spacer

Install the included network cable with keystone in the opened space. Do this by placing the keystone in the open space and tilting it upwards until the keystone locks into the device while being flush with the back panel.

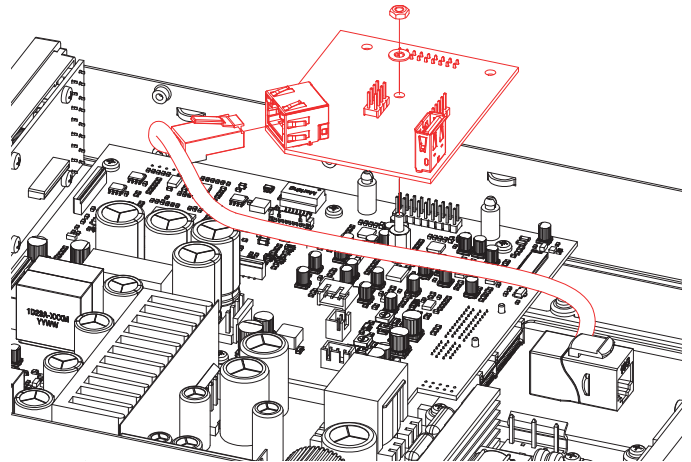

Step 7: Placement

Connect the RJ45 connector on the other end of the cable on the ANI before placing the ANI into the device.

Fix the ANI into the amplifier by simply clicking it in place using the snap-in spacers. Once positioned correctly, securing can be done by putting the supplied washer and nut and tightening it.

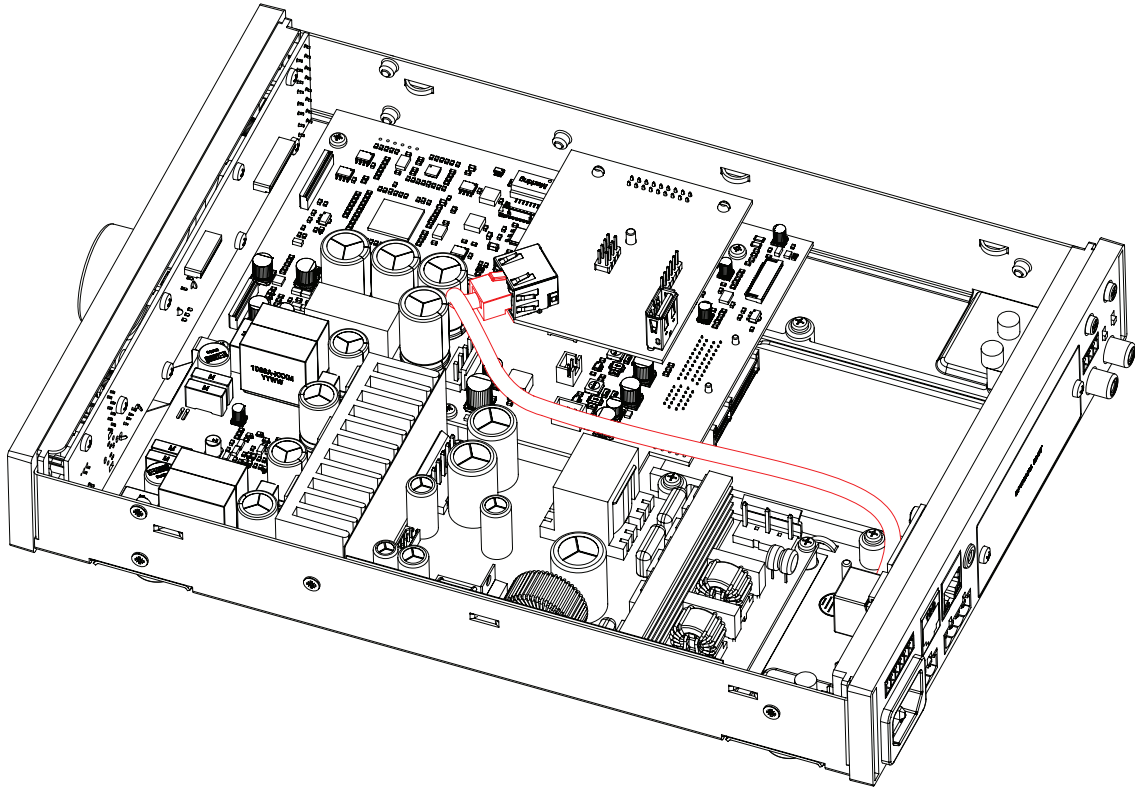

Step 8: Cable management

Use the included cable tie's to lock the network cable into place to avoid it moving and touching the heatsinks.

Double check whether all internal wires are well connected and well positioned. After all connections are successfully made, the top cover of the amplifier can be re-fitted and fixed using the original screws.

Step 9: Up to date

To guarantee the correct functioning of the amplifier with the installed ANI Dante network audio interface, verify that the current MFA firmware is version 1.2.6 or higher. The firmware version of your amplifier is shown on the front LCD display when powering on the amplifier. When it is not Dante-ready, you can update your amplifier over-the-air. Check for the latest firmware update.

To automatically add the Dante channels to your amplifier, apply a factory reset to MFA after the physical installation of the ANI Dante network audio interface and firmware update or verification. For factory reset procedures, please refer to the product user manual.

Result:

Your MFA is now equipped with a Dante network audio interface, allowing new networked audio possibilities.

For more information about the functions, the connections or Dante in general, refer to the quick start guide or Dante controller user guide.

ANI44XT

Installation Guide SMA/SMQ/PMQ

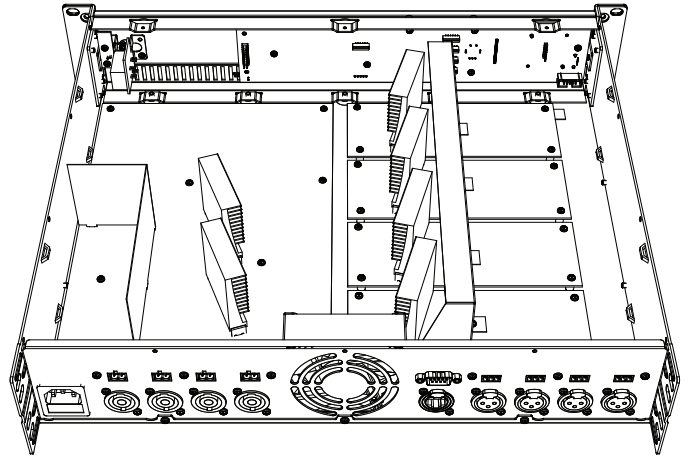
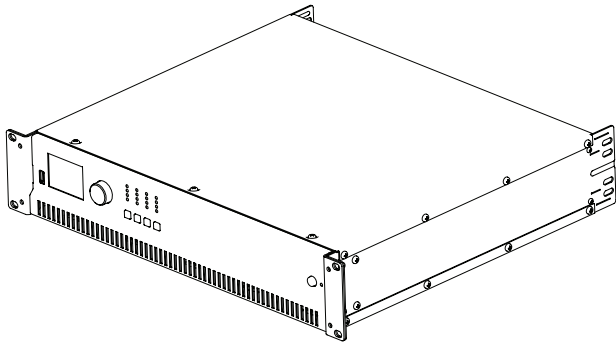

Step 1: ATTENTION

Make sure the amplifier is powered off and the power inlet is disconnected from the mains power before the enclosure is opened

Step 2

Open the amplifiers' enclosure by carefully removing the screws from the top panel of the device, and lifting it.

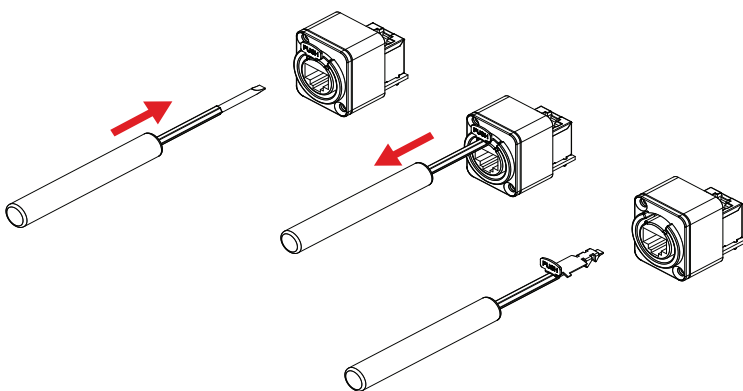

Step 3

Step 3.1

Remove the latch from the Ethernet compatible connector on the connection board by putting a flat screwdriver underneath the clip and pulling back screwdriver and latch together. This will simplify the assembly of the ethernet connection board in the back of the unit.

Step 3.2

Remove the cover plate at the 'EXPANSION' hole on the back of the amplifier. The ethernet connection board of the ANI shall be installed on this position.

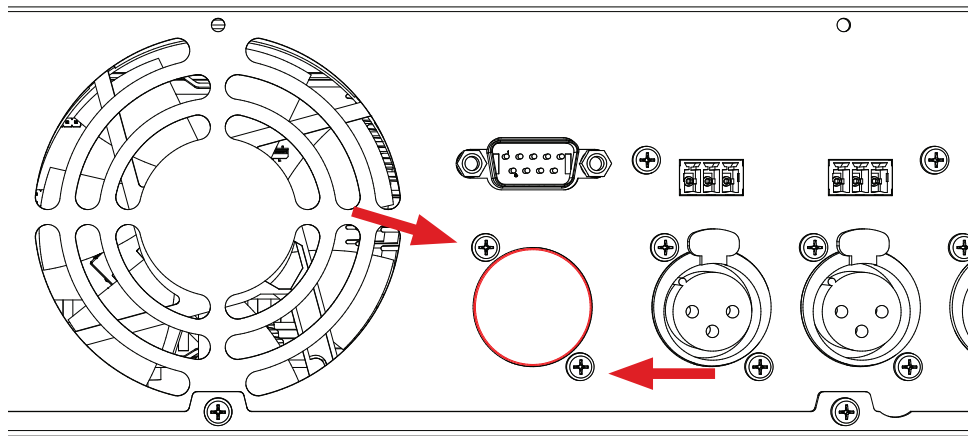

Step 3.3

Insert the ethernet connection board from the inner side of the amplifier to the 'EXPANSION' hole, and fix it by inserting and tightening the two supplied screws. The latch removed from the connector in step 3.1 can now get inserted to the connector again by simply inserting and pushing it into the right position.

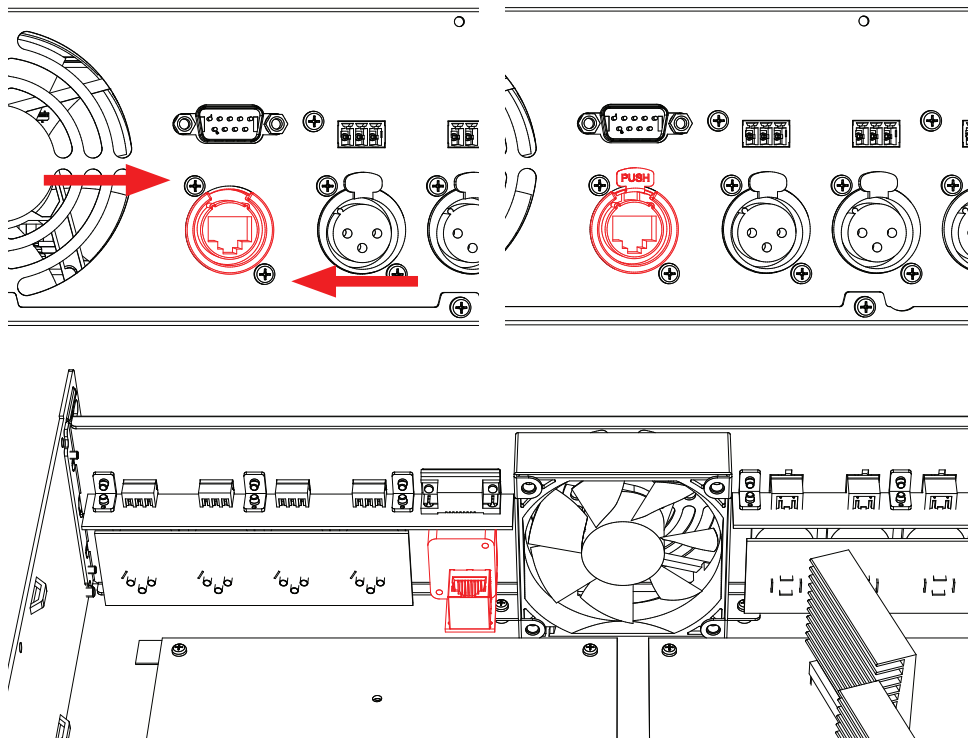

REMARK

Detaching the upper input board (containing terminal block and RS-232 sockets) may facilitate the installation. Make sure it is well fastened again afterwards.

Step 4

Once the Ethernet connection PCB is correctly installed, the supplied ethernet connection cable shall be plugged to the RJ45 connection socket in the inner side of the ethernet connection board. The network cable has a length of 66cm.

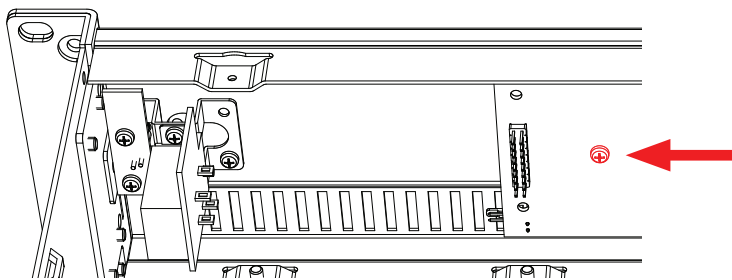
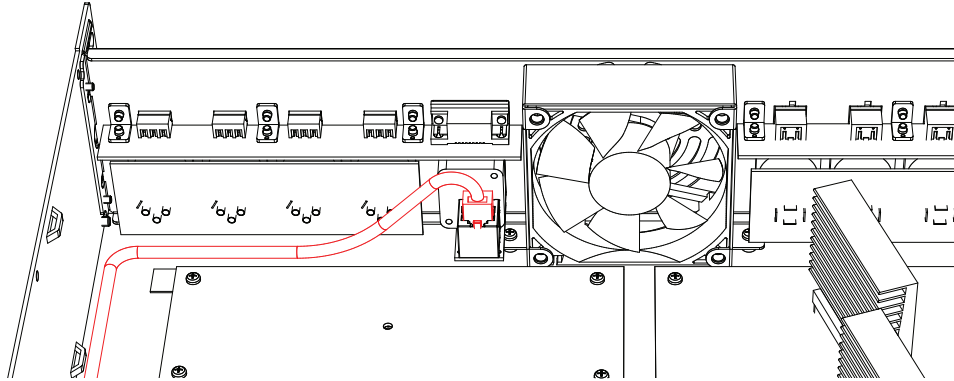

Step 5

Mount the ANI main interface board into the amplifier:

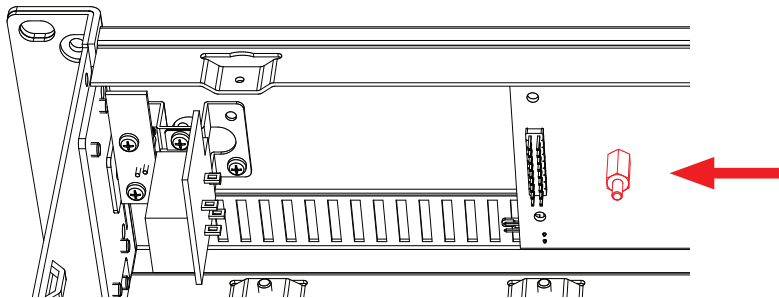

Step 5.1

Remove the screw on the left most side of the front display board of the amplifier and replace it by the supplied M3 spacers.

Step 5.2

Insert both supplied nylon snap-in spacers into the appropriate holes in the ANIxx main interface board as indicated in the below image.

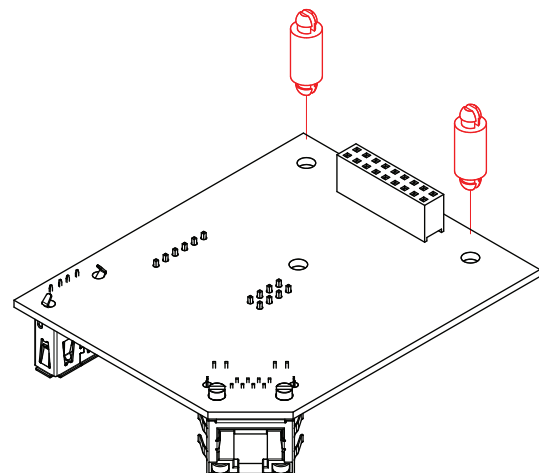

Step 5.3

Connect the cable from the ethernet connection board to the RJ45 jack on the main interface board and position the cable as indicated in the below image. Correct positioning of the cable is important to avoid touching heating amplifier parts and to avoid obstruction of the internal air-flow of the device. The networking cable shall be fixed to the internal provided tabs using the supplied cable tie's.

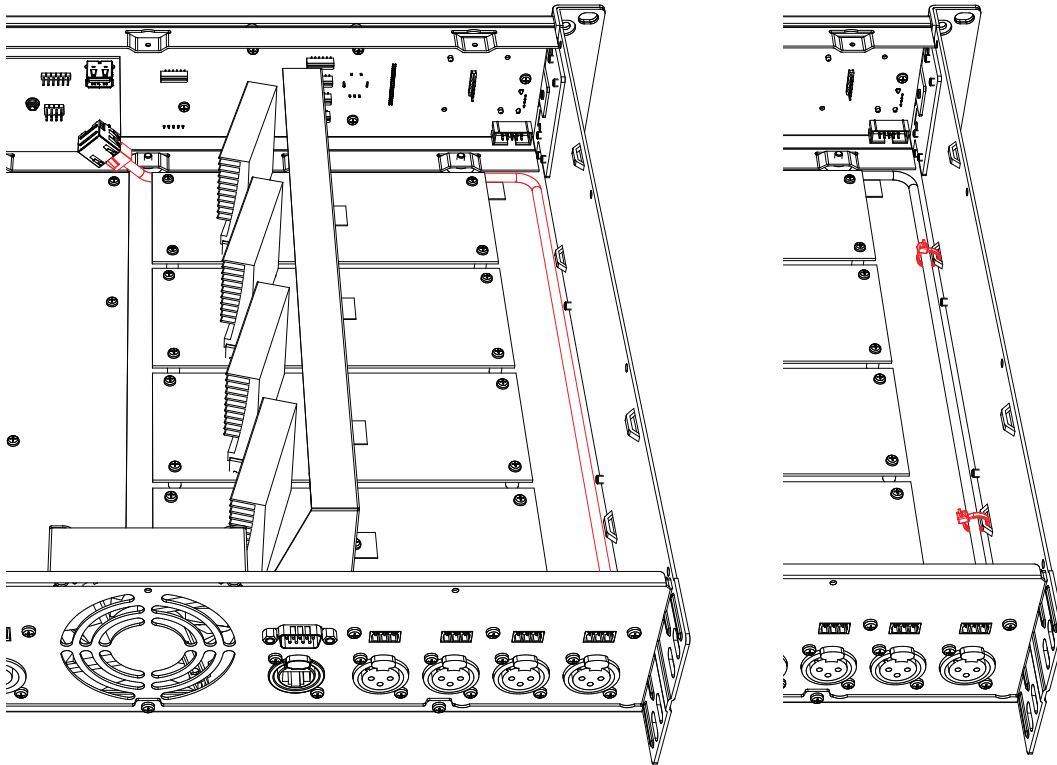

Step 6

Fix the ANI main interface board into the amplifier by simply clicking it onto the front display board using both snap-in spacers. It is important that the main board is supported when the ANI is attached. Make sure the female pin-header on the main interface board is well positioned and matching the male counterpart on the front display board of the amplifier. Once positioned correctly, securing can be done by putting the supplied washer and nut and tightening it.

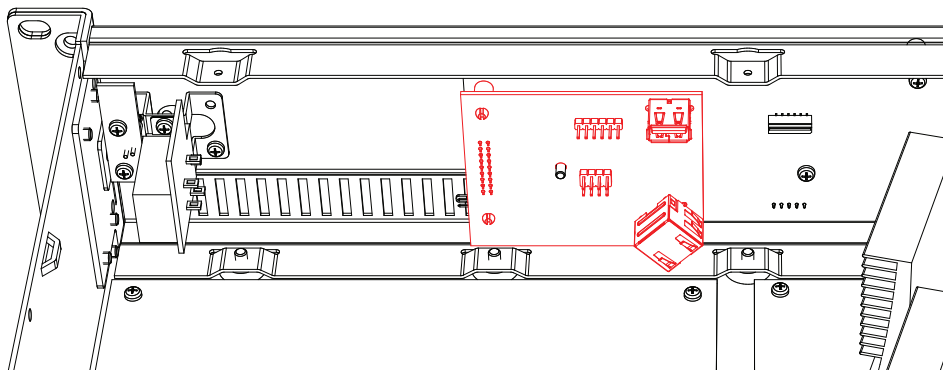

Step 7:

Double check whether all internal wires are well connected and well positioned. After all connections are successfully made, the top cover of the amplifier can be re-fitted and fixed using the original screws.

Step 8:

To guarantee the correct functioning of the amplifier with the installed ANI Dante network audio interface, verify whether the current running firmware version fully supports this interfaces functions.

For SMA/SMQ amplifiers, firmware shall be version 2.08 or higher

For PMQ amplifiers, firmware shall be version 2.01 or higer

The firmware version of your amplifier is shown under 'GENERAL SETUP' 'Info and ANI Info'. When it is not Dante ready, download and install the latest firmware using the AUDAC System Manager.

To automatically add the Dante channels to your amplifier, apply a factory reset to SMA/SMQ/PMQ after the physical installation of the ANI Dante network audio interface and firmware update or verification. For factory reset procedures, please refer to the product user manual.

Result:

Your amplifier is now equipped with a Dante network audio interface, allowing new networked audio possibilities.

For more information about the functions, the connections or Dante in general, refer to the quick start guide or Dante controller user guide.

ANI44XT

Installation Guide VEXO

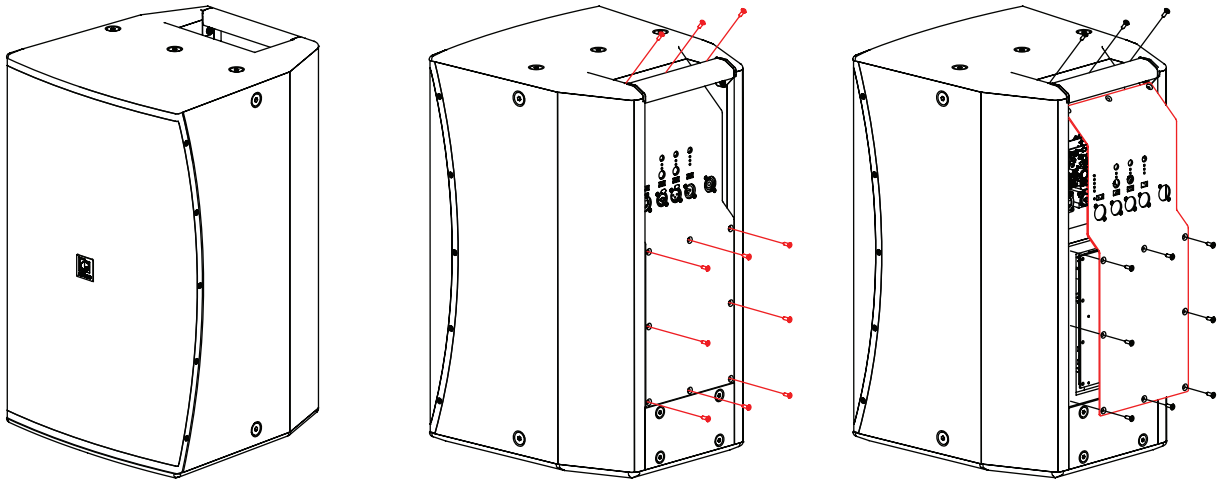

Step 1: ATTENTION

Make sure the speaker is powered off and the power inlet is disconnected from the mains power before the enclosure is opened.



HANDLE WITH CARE!

Various cables are mounted on the circuit boards that are attached to the back plate. Be careful when removing the back plate that no cables or connectors are damaged.

The various cables can be temporarily disconnected to facilitate the installation.

Step 2:

Open the speakers' enclosure by carefully removing the screws from the back panel of the device. Once removed, the back cover can be removed. All the necessary PCBs are mounted on the back plate.

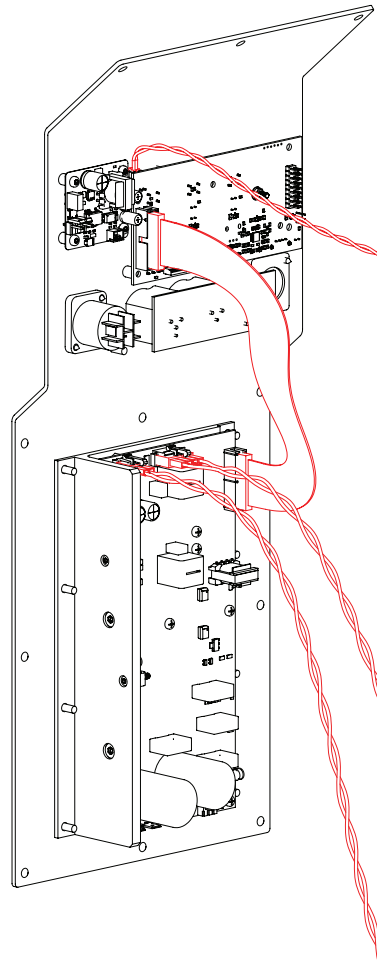

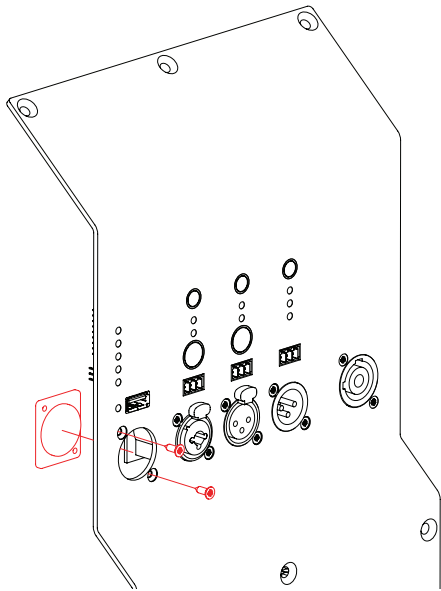

Step 4:
Remove the blind plate cover at the back of the device by unscrewing the two screws.

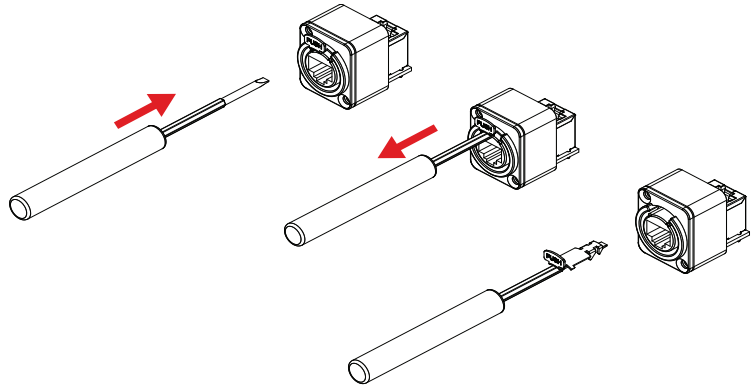

Step 5.1:
Remove the latch from the Ethernet compatible connector on the connection board by putting a flat screwdriver underneath the clip and pulling back screwdriver and latch together. This will simplify the assembly of the ethernet connection board in the back of the unit.

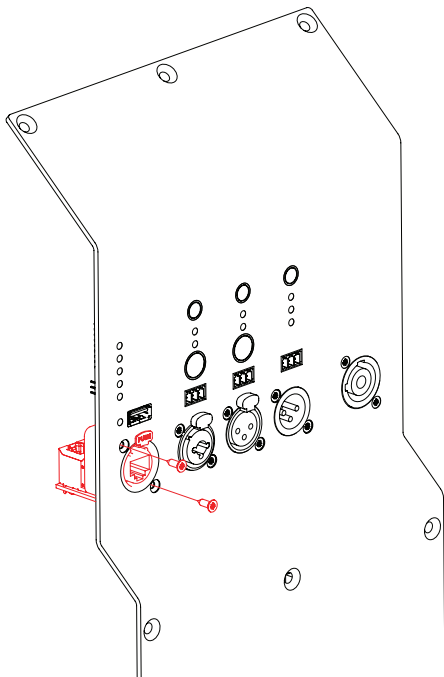

Step 5.2:
Insert the ethernet connection board from the inner side of the amplifier to the 'EXPANSION' hole, and fix it by inserting and tightening the two supplied screws. The latch removed from the connector in step 5.1 can now get inserted to the connector again by simply inserting and pushing it into the right position.

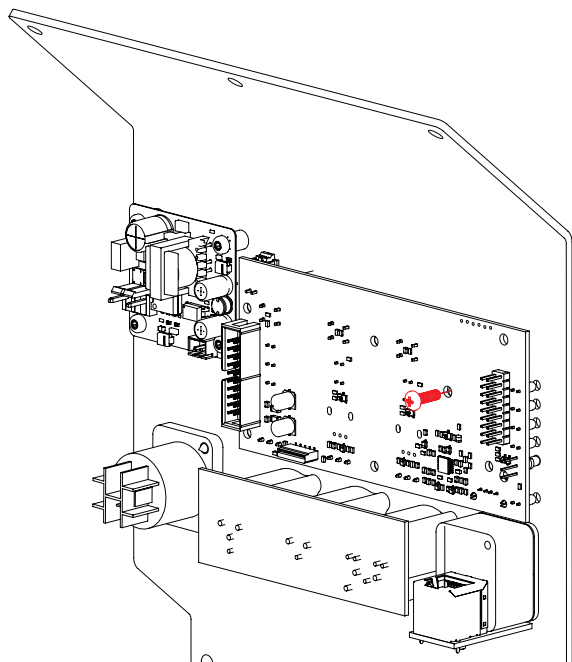

Step 6:
Remove the indicated screw from the main circuit board.

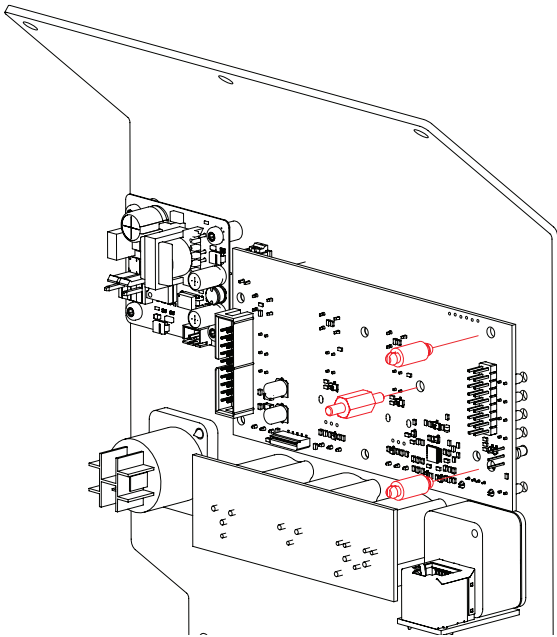

Step 7:

Insert the M3 spacer and both nylon snap-in spacers into the appropriate holes in the circuit board as indicated in the image above.

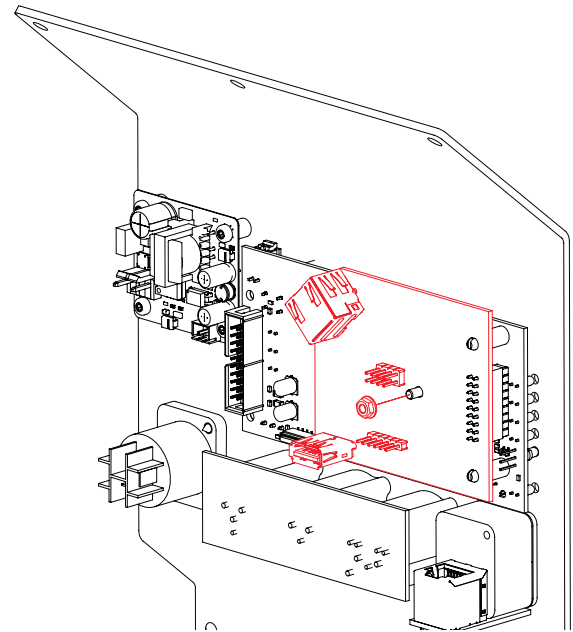

Step 8:

Fix the ANI into the amplifier by simply clicking it in place using the snap-in spacers. It is important that the main board is supported when the ANI is attached. Once positioned correctly, securing can be done by putting the supplied washer and nut and tightening it.

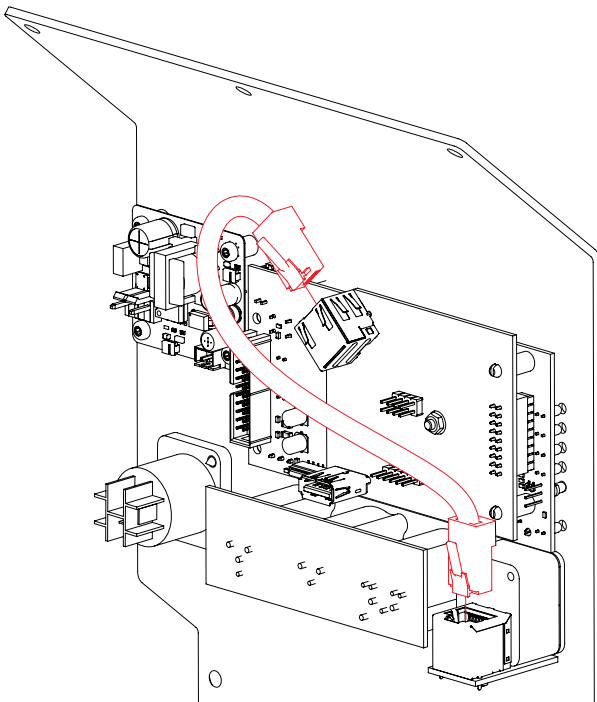

Step 9:

Once the ANI is installed, the provided Ethernet connection cable can be inserted into the RJ45 connection sockets. Connect the cable from the ethernet connection board to the RJ45 jack on the main interface board. The Ethernet cable has a length of 24cm.

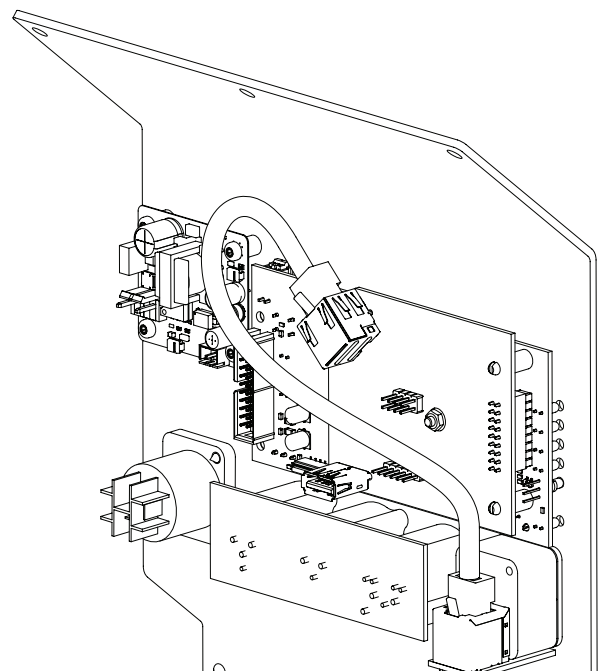

Step 10:

Connect all possible disconnected wires to their original location after installing the ANI. Double check whether all internal wires are well connected and well positioned. After all connections are successfully made, the back of the device can be re-fitted and fixed using the original screws.

Additional information

Technical specifications

Number of inputs	ANI44XT	4
Number of output	ANI44XT	4
Communication Protocol	Audinate DANTE Network layer 3 IP protocol	
Sampling frequency	48 kHz	
Sampling bit depth	24-bit	
Latency	2 ~ 5 ms	
Connection	Ethercon compatible RJ45 connector	
Network specification	Standard 100 Mbit / 1 Gbit network	
Mounting	Integration in amplifier/ speaker chassis	
Power consumption	1.5 Watt	
Weight	0.090 Kg	
Compatible devices (implementation)	ANI44XT	SMQ/PMQ/SMA Series WaveDynamics™ amplifiers
	ANI44XT	MFA Series
	ANI44XT	VEXO Series
Protocol (DANTE) compatible devices	https://www.audinate.com/products/dante-enabled	
Programming DANTE network: Dante controller	https://www.audinate.com/products/software/dante-controller	

CAUTION - SERVICING:

This product contains no user serviceable parts. Refer all servicing to qualified service personnel. Do not perform any servicing (unless you are qualified to)

EC DECLARATION OF CONFORMITY

This product conforms to all the essential requirements and further relevant specifications described in following directives: 2014/30/EU (EMC) and 2014/35/ EU (LVD)

WASTE ELECTRICAL AND ELECTRONIC EQUIPMENT (WEEE)

The WEEE marking indicates that this product should not be disposed with regular household waste at the end of its life cycle. This regulation is created to prevent any possible harm to the environment or human health.

This product is developed and manufactured with high quality materials and components which can be recycled and/or reused. Please dispose this product at your local collection point or recycling center for electrical and electronic waste. This will make sure that it will be recycled in an environmentally friendly manner, and will help to protect the environment in which we all live.

CAUTION

The symbols shown are internationally recognized symbols that warn about potential hazards of electrical products. The lightning flash with arrow point in an equilateral triangle means that the unit contains dangerous voltages. The exclamation point in an equilateral triangle indicates that it is necessary for the user to refer to the users manual.



These symbols warn that there are no user serviceable parts inside the unit. Do not open the unit. Do not attempt to service the unit yourself. Refer all servicing to qualified personnel. Opening the chassis for any reason will void the manufacturer's warranty. Do not get the unit wet. If liquid is spilled on the unit, shut it off immediately and take it to a dealer for service. Disconnect the unit during storms to prevent damage.

CAUTION:

ALWAYS KEEP THESE INSTRUCTIONS. NEVER THROW THEM AWAY

ALWAYS HANDLE THIS UNIT WITH CARE

HEED ALL WARNINGS

FOLLOW ALL INSTRUCTIONS

NEVER EXPOSE THIS EQUIPMENT TO RAIN, MOISTURE, ANY DRIPPING OR SPLASHING LIQUID. AND NEVER PLACE AN OBJECT FILLED WITH LIQUID ON TOP OF THIS DEVICE

NO NAKED FLAME SOURCES, SUCH AS LIGHTED CANDLES, SHOULD BE PLACED ON THE APPARATUS

DO NOT PLACE THIS UNIT IN AN ENCLOSED ENVIRONMENT SUCH AS A BOOKSHELF OR CLOSET. ENSURE THERE IS ADEQUATE VENTILATION TO COOL THE UNIT. DO NOT BLOCK THE VENTILATION OPENINGS.

DO NOT STICK ANY OBJECTS THROUGH THE VENTILATION OPENINGS.

DO NOT INSTALL THIS UNIT NEAR ANY HEAT SOURCES SUCH AS RADIATORS OR OTHER APPARATUS THAT PRODUCE HEAT.

DO NOT PLACE THIS UNIT IN ENVIRONMENTS WHICH CONTAIN HIGH LEVELS OF DUST, HEAT, MOISTURE OR VIBRATION

THIS UNIT IS DEVELOPED FOR INDOOR USE ONLY. DO NOT USE IT OUTDOORS

PLACE THE UNIT ON A STABLE BASE OR MOUNT IT IN A STABLE RACK

ONLY USE ATTACHMENTS & ACCESSORIES SPECIFIED BY THE MANUFACTURER

UNPLUG THIS APPARATUS DURING LIGHTNING STORMS OR WHEN UNUSED FOR LONG PERIODS OF TIME

ONLY CONNECT THIS UNIT TO A MAINS SOCKET OUTLET WITH PROTECTIVE EARTHING CONNECTION

THE MAINS PLUG OR APPLIANCE COUPLER IS USED AS THE DISCONNECT DEVICE, SO THE DISCONNECT DEVICE SHALL BE READILY OPERABLE

USE THE APPARATUS ONLY IN MODERATE CLIMATES

